

# MT 3100<sub>up</sub> MT 3200<sub>up</sub>

EASY - ALU



PLUS version



Equilibratrici elettroniche a display  
per autovetture, trasporto leggero e motoveicoli  
*Electronic balancing with display  
for cars, lightweight transport vehicles and motor vehicles*



# MT 3100up MT 3200up

## EASY - ALU

### VERSIONI DISPONIBILI - AVAILABLE VERSION:

**MT3200 up C PLUS:** Versione con sistema di **serraggio automatico PNEULOCK**, introduzione automatica di diametro e distanza ruota. Freno di stazionamento elettrico.  
*Version with **automatic clamping system PNEULOCK**, with automatic input of wheel diameter and distance. Electrical clamping brake.*

**MT3200 up PLUS:** Versione con sistema di serraggio ruota manuale, introduzione automatica di diametro e distanza ruota. Freno di stazionamento elettrico.  
*Version with manual wheel clamping system with automatic input of wheel diameter and distance. Electrical clamping brake.*

**MT3200 up:** Versione con sistema di serraggio ruota manuale, introduzione automatica di diametro e distanza ruota.  
*Version with manual wheel clamping system with automatic input of wheel diameter and distance.*

**MT3100 up:** Versione con sistema di serraggio ruota manuale, introduzione manuale di diametro e distanza ruota.  
*Version with manual wheel clamping system with manual input of wheel diameter and distance.*

Tutte le versioni sono normalmente fornite con protezione ruota e lancio automatico.  
*All models are normally supplied with automatic spin by pushing down wheel guard.*

### TUTTI I MODELLI ALL MODELS

#### 1. DISPLAY E PIANALE PORTA PESI - DISPLAY AND WEIGHT HOLDER TRAY

**Visualizzatore a doppio display**, permette una selezione rapida ed intuitiva dei programmi di equilibratura e l'accesso immediato alle funzioni di lavoro più comuni.

Pianale portapesi ergonomico e spazioso per contrappesi ed accessori da lavoro realizzato con materiale ad elevata resistenza.

**A double display control panel** enables a quick and intuitive selection of the balancing mode and immediate access to the most common operating functions.

*Ergonomic and spacious tray in highly resilient material for counterweights and work accessories.*



#### 2. GRUPPO DI LANCIO - SPIN UNIT

Gruppo di lancio derivato dai modelli superiori, fornisce caratteristiche di **precisione e funzionalità** tipici di equilibratrici di fascia alta: tempo di ciclo ridotto, misura su ruote con peso fino a 75 kg ed equilibratura di ruote con offset interno fino a 275 mm senza l'utilizzo di distanziali aggiuntivi.

**L'innovativa motorizzazione a manutenzione zero ne assicura la massima affidabilità.**

*Spin unit derives from the superior models of the B-Series and **provides functional features** typical of the upper models: reduced cycle time, measuring wheels weighing up to 75 kg and wheel balancing with inside offset of up to 275 mm without using additional spacer. **The innovative drive and zero maintenance ensure maximum reliability.***







### 3. BASE CON PIEDE (optional) - SUPPORT BASE (optional)

Piede per **equilibrare ruote fino a 50 kg** di peso senza dover fissare la macchina al suolo.

Front support base for **balancing wheels up to 50 kg** without fastening the machine to the ground.





#### 4. ACQUISIZIONE DATI RUOTA - WHEEL DIMENSION DETECTION

**Acquisizione elettronica di diametro e distanza** con funzione AUTOSELECT che attiva automaticamente i programmi di equilibratura evitando le selezioni da tastiera (non nella versione 3100 up).

*Electronic input of wheel diameter and distance* with AUTOSELECT function which automatically activates the balancing programmes, avoiding keypad selection (no in the 3100 up version).



#### 5. PESI ADESIVI - ADHESIVE WEIGHTS

**Tre sistemi per il posizionamento dei pesi adesivi:** con clip portapesi (\*), con indicatore laser a ore 6 (\*) o manualmente a ore 12.

*Three modes to position the adhesive weights:* with the weight holder clip (\*), with the 6 o'clock laser indicator (\*) or manually at 12 o'clock.



\*Funzione o accessorio a richiesta. Vedi tabella / *Optional function or accessory. See diagram*







## 6. TL3

**Rilevatore sonar TL3** per la misura automatica della larghezza ruota senza contatto (\*).

*TL3 automatic sensor for measurement of wheel width (\*).*



## 7. POSIZIONAMENTO AUTOMATICO - AUTO POSITIONING

**Posizionamento automatico (RPA)** della ruota nel punto di applicazione del peso di equilibratura e freno di stazionamento elettrico (\*).

*Automatic wheel positioning (RPA) in the point where the balancing weight has to be applied and electrical positioning brake (\*).*



**L'illuminatore led** illumina l'area di lavoro per facilitare le operazioni di pulizia del cerchione e l'applicazione dei contrappesi. I contrappesi possono essere posizionati con estrema velocità utilizzando il puntatore laser a ore 6 (**LASER LINE SYSTEM**) (\*).

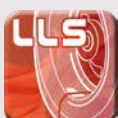

*LED spotlight to light-up the work area and make it easier to clean the rim, check the wheel and apply weights. The adhesive weights can be positioned extremely rapidly using the laser pointer at 6 o'clock (**LASER LINE SYSTEM**) (\*).*



## 9. FRENO DI BLOCCAGGIO (A RICHIESTA) PEDAL WHEEL HOLDER (OPTIONAL)

Freno di bloccaggio albero porta ruota a pedale, facilita le operazioni di bloccaggio e sbloccaggio ruota e l'applicazione dei contrappesi (\*).

*Pedal wheel holder shaft locking brake, makes easier both the wheel clamping and unclamping options as well as the application of weights (\*).*



### 10. BLOCCAGGIO RUOTA - WHEEL CLAMPING

#### DISPONIBILE NELLE DUE VERSIONI:

- Con **bloccaggio ruota manuale** con ghiera rapida.
- Con **nuovo sistema automatico pneumatico di bloccaggio ruota PNEULOCK**, che riduce i tempi di lavoro e incrementa la precisione del centraggio

#### AVAILABLE IN TWO VERSIONS:

- With **manual wheel clamping** with quick ring.
- With **new PNEULOCK automatic air wheel clamping system**, with constant torque, for shorter operative times and higher centering accuracy



## PNEULOCK

**BLOCCAGGIO AUTOMATICO VELOCE E FACILE DA USARE:  
MENO SFORZO - MENO TEMPO**

**AUTOMATIC CLAMPING EASY AND QUICK TO USE:  
SAVE EFFORT - SAVE TIME**

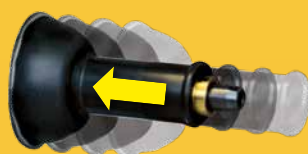

### Programmi speciali per tutti i modelli Special Programmes for all models



#### HIDDEN WEIGHT

Programma per nascondere il peso dietro le razze per un migliore impatto estetico del cerchio.  
*Programme for concealing counterweights behind spokes for improved wheel aesthetics.*



#### OPT FLASH

Programma che indica la posizione di montaggio ideale tra cerchio e pneumatico al fine di ridurre lo squilibrio complessivo della ruota.  
*Programme indicating ideal wheel/tyre assembly position to reduce overall wheel imbalance.*



#### EASY WIDTH

Calcolo automatico della larghezza ruota anche in assenza del **sensore esterno TL3**.  
L'equilibratrice fa una previsione della larghezza ruota riducendo i tempi operativi (\*).  
*Automatic calculation of the width even if the TL3 external sensor is not present.  
The wheel balancer calculates the width by reducing the operational time (\*).*



# MONDOLFO FERRO

## MODELLO MODEL



MT 3100up					✓					✓
MT 3200up				✓	✓	✓	✓		✓	✓
MT 3200up PLUS		✓	✓	✓	✓	✓		✓	✓	
MT 3200up C PLUS	✓	✓	✓	✓	✓	✓		✓	✓	



STANDARD



OPTIONAL

## Dati tecnici Technical data



75 Kg	10" - 28" 1" - 35"	1,5" - 20"	600 mm	1117 mm	85 Kg	115/230V 1Ph - 50/60Hz	90 ÷ 130 rpm	100 W	7÷10 bar (Version C)
-------	-----------------------	------------	--------	---------	-------	---------------------------	--------------	-------	-------------------------

## Dimensioni Dimensions

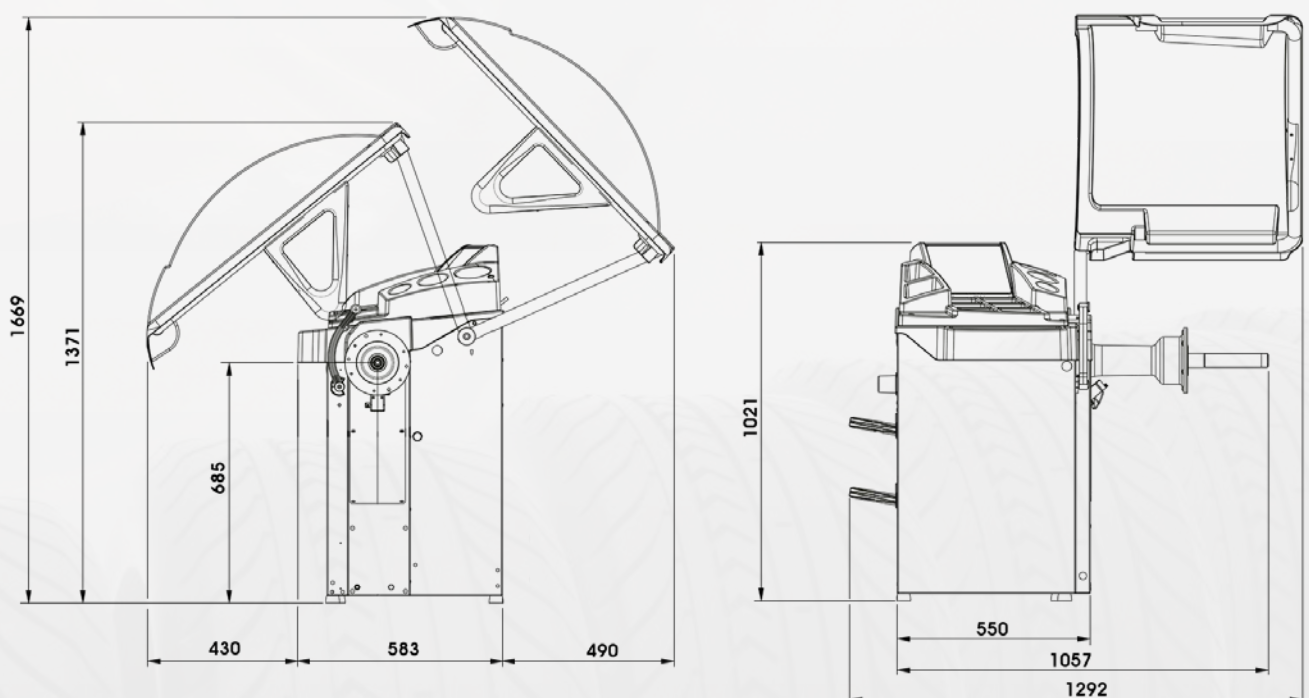

## Dotazione Equipment



## Accessori raccomandati Recommended accessories

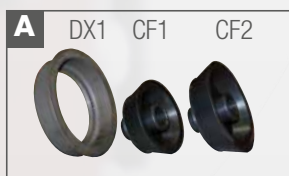

### A. DX\CBF-> 8-21100141

Accessorio di centraggio per furgoni e fuoristrada con foro centrale Ø 117÷173 mm  
*Centring accessory for van and off-road wheels with central hole with Ø 117÷173 mm*

### B. CB-> 8-21100191

Freno a pedale  
*Pedal brake*

### C. CLIP-> 8-21100159

Terminale portapesi STD ALU  
*STD ALU weight-holder terminal*

### G. -> 8-21100238

Illuminatore interno ruota a LED e puntatore LASER  
*STD ALU weight-holder terminal*

### D. TL3-> 8-21100232

Rilevatore larghezza ruota  
*Automatic sensor wheel width*

### F. FRU-> 8-21100091

Flangia universale per ruote vettura senza foro centrale  
*Universal flange for wheels without central hole*

### E. WLO -> 8-21100230

Sollevatore effetto "senza peso"  
*"Weightless effect" wheel lifter*

### H. PL50-> 8-21100158

Piede per ruote fino a 50 kg  
*Base for wheels up to 50 kg*

### I. LASER PLANE KIT -> 8-21120022

Puntatore laser integrato nel braccio rilevatore digitale interno, diametro/distanza  
*Laser pointer built in the internal digital detector arm; diameter/distance*

Per maggiori informazioni consultare il catalogo accessori / For more information, please consult the accessories catalogue